

Stainless Steel
High Vacuum Angle/In-line Valve

Series XMH, XYH

Manual Valve/Bellows Seal



How to Order

Angle type

XMH — **16** □ — □ — □

In-line type

XYH — **25** □ — □ — □

1 2 3



1. Flange size

Size	XMH	XYH
16	●	—
25	●	●
40	●	●
50	●	●

2. Flange type

XMH

Symbol	Type	Applicable flange size
Nil	KF (NW)	16, 25, 40, 50
C	CF	16 (034), 40 (070)

XYH

Nil	KF (NW)	25, 40, 50
-----	---------	------------

3. Seal material, part number and specification

• Seal material

Symbol	Seal material	Compound No.
Nil	FKM	1349-80*
N1	EPDM	2101-80*
P1	Barrel Perfluoro®	70W
Q1	Kalrez®	4079
R1	Chemraz®	SS592
R2		SS630
R3		SSE38
S1	VMQ	1232-70*
T1	FKM for Plasma	3310-75*
U1	ULTIC ARMOR®	UA4640

*: Produced by Mitsubishi Cable Industries, Ltd.

• Part nos. for seal material replacement and leakage specification

Symbol	Replacement part ^{Note 2)}	Leakage Pa·m ³ /s or less ^{Note 1)}	
		Internal (2) ^{Note 2)}	External (3) ^{Note 2)}
Nil	—	1.3 x 10 ⁻¹⁰ (FKM)	1.3 x 10 ⁻¹¹ (FKM)
A	2, 3	1.3 x 10 ⁻⁸	1.3 x 10 ⁻⁹
B	2	1.3 x 10 ⁻⁸	1.3 x 10 ⁻¹¹ (FKM)
C	3	1.3 x 10 ⁻¹⁰ (FKM)	1.3 x 10 ⁻⁹

Note 1) Values at ambient temperatures, excluding gas permeation.

Note 2) Refer to parts number of "Construction" on the page 49 for changed part. Number indicates parts number of "Construction" accordingly.

To order something else "Nil" (standard), list the symbols starting with "X", followed by each symbol for "seal material" and then "changed parts" at last.

Ex.) XMH-16-XN1A

Specifications

Model		XMH-16	XMH-25 XYH-25	XMH-40 XYH-40	XMH-50 XYH-50
Flange (valve) size		16, CF034	25	40, CF070	50
Valve type		Manual type			
Fluid		Inactive gas under vacuum			
Operating temperature °C		5 to 150			
Operating pressure Pa		Atmospheric pressure to 1×10^{-6}			
Conductance ℓ/s <small>Note 1)</small>		5	14	45	80
Leakage $\text{Pa}\cdot\text{m}^3/\text{s}$	Internal	1.3×10^{-10} { 1×10^{-10} } at ambient temperature, excluding gas permeation			
	External	1.3×10^{-11} { 1×10^{-11} } at ambient temperature, excluding gas permeation			
Flange type		KF (NW), CF	KF (NW)	KF (NW), CF	KF (NW)
Principle materials		Body: SCS13 (Conforms to Stainless steel SUS304) Bellows: Stainless steel SUS316L Bellows holder: Stainless steel SUS304. FKM (Standard seal material)			
Pilot torque N·m		$0.1 \leq$	$0.15 \leq$	$0.35 \leq$	$0.5 \leq$
Handle revolutions		5	7	10	13
Service life (million cycles)		0.1			
Weight kg <small>Note 2)</small>	XMH	0.31 (0.35)	0.57	1.35 (1.71)	2.02
	XYH	—	0.62	1.37	2.42

Note 1) Conductance is the value for the molecular flow of an elbow having the same dimensions.

Note 2) Figures in () indicates the weight of CF, conflate fittings.

Construction

XMH/Angle type

XYH/In-line type

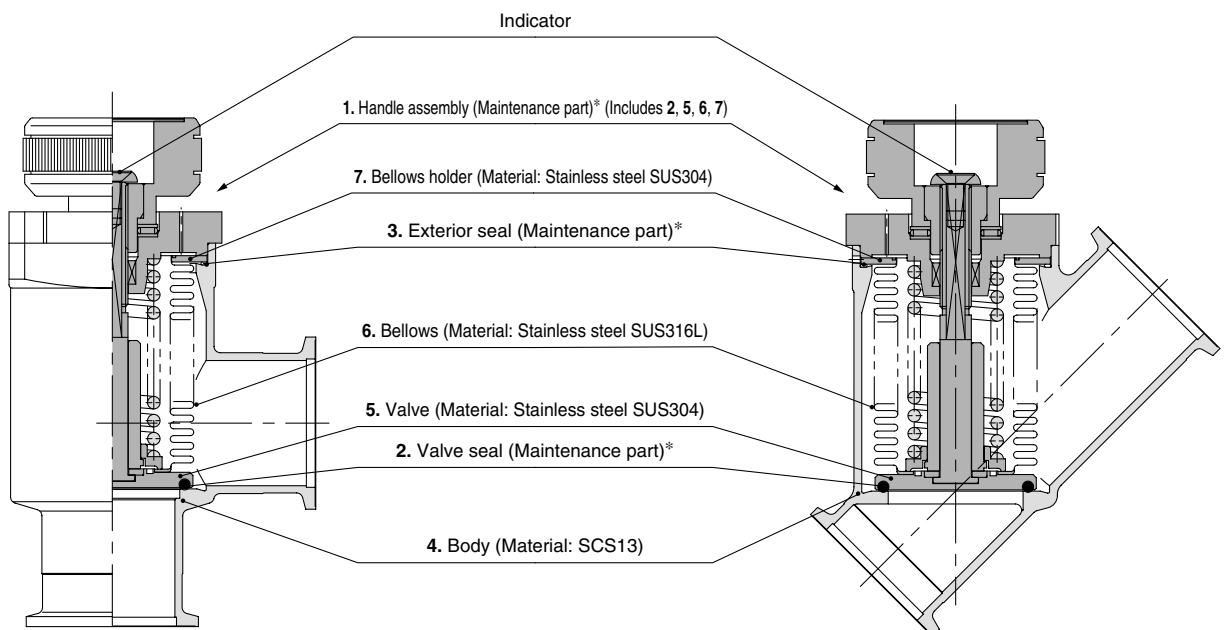

Series XMH, XYH

Dimensions

XMH/Angle type

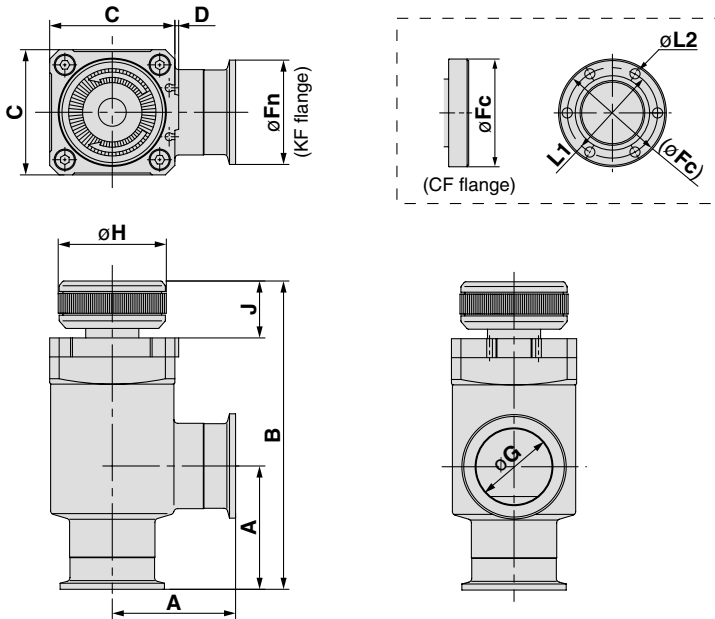

Model	A	B	C	D	F _n	F _c	G	H	J	P.C.D L1	L2
XMH-16	40	100.5	38	1	30	34	17	35	18	P.C.D 27	6- ϕ 4.4
XMH-25	50	114	48	1	40	—	26	40.5	21.5	—	—
XMH-40	65	162.5	66	2	55	70	41	57	30	P.C.D 58.7	6- ϕ 6.6
XMH-50	70	179.5	79	2	75	—	52	70	35	—	—

XYH/In-line type

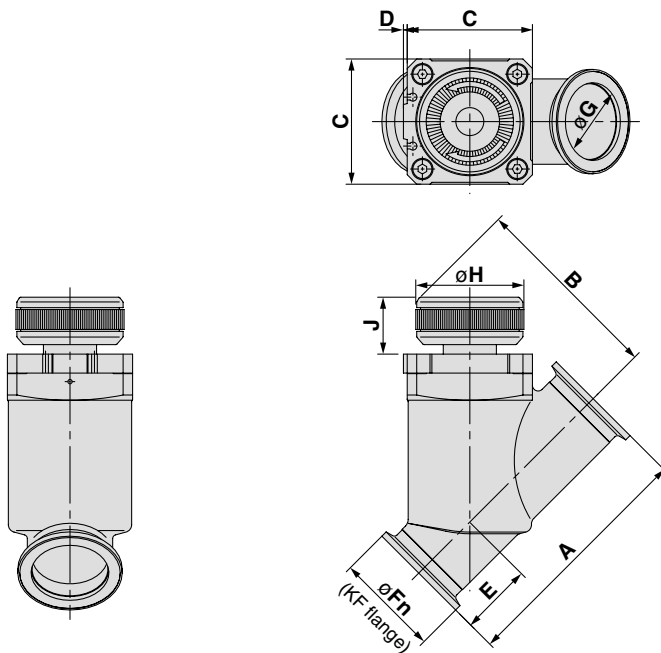

Model	A	B	C	D	E	F _n	G	H	J
XYH-25	100.2	75.8	48	1	23.5	40	26	40.5	21.5
XYH-40	130	102.5	66	2	38	55	41	57	30
XYH-50	178	119	79	2	53	75	52	70	35

1 Seal Materials Available

FKM (fluoro rubber)

With low outgassing, low permanent-set and low gas permeation rate, this is the most popular seal material for high vacuum. SMC's seal material has undergone a high vacuum degassing process.

Kalrez®

This is an elastomer with the most outstanding resistance to heat and chemicals, but its permanent-set is large, and special caution is required when used in other than static applications. Variations are available with improved plasma (O₂, CF₄) and particulate resistance. Therefore, it is advisable to select types based upon the application.

Chemraz®

This material has excellent chemical and plasma resistance and has slightly higher heat resistance than FKM. Several variations of Chemraz® are available and it is advisable to make a selection based upon the particular plasma being used and other conditions, etc.
* Chemraz® is a registered trade mark of Greene, Tweed & Co.

Silicone

This material is relatively inexpensive, has good plasma resistance and can be used at high temperatures, but its gas permeation rate is large.

2 Shaft Sealing Method

Bellows

SMC valves employ formed-bellows that produce few particulates yet have very long life. Welded-bellows are not used despite their longer life because they generate many more particulates. The cleaning and durability of SMC bellows have been improved through consistent control of surface treatment and handling.

O-ring, etc.

Due to entrainment of gases and generation of particulates, vacuum performance is somewhat inferior to the bellows type. However, high speed operation is possible and durability is comparatively high. The SMC sealing system has an especially long life because, it employs seals that are specially designed to retain the low vapor pressure grease while keeping particulates out.

3 Response time/Operation time

Valve opening

The time from the application of voltage to the actuation solenoid valve until 90% of the valve (XL□) stroke has been completed is the valve opening response time. Valve opening operation time indicates the time from the start of the stroke until 90% of movement has been completed. Both of these become faster as the operating pressure is increased.

Valve closing

The time from the cut off of power to the actuation solenoid valve until 90% of the valve (XL□) return stroke has been completed is the valve closing response time. Valve closing operation time indicates the time from valve opening until 90% of return movement has been completed. Both of these become slower as the operating pressure is increased.

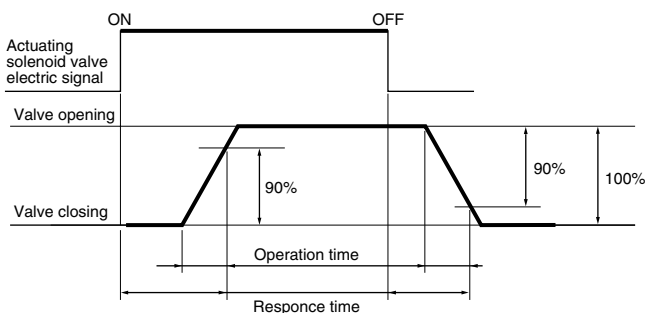

4 Molecular flow conductance

Orifice conductance

In the case of a ϕA (cm²) hole in an ultra-thin plate, the conductance "C" results from "V" the average velocity of the gas, "R" the gas constant, "M" the molecular weight and "T" the absolute temperature. From the formula $C=VA/4=(RT/2\pi M)^{0.5}A$, the conductance for 1 cm² is $C=11.6A$ l/sec, at an air temperature of 20°C.

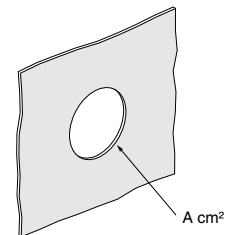

Cylinder conductance

With length "L" (cm) and diameter "D" (cm) where $L \gg D$, from the formula $C=(2\pi RT/M)^{0.5}D^3/6L$, the conductance $C=12.1D^3/L$ l/sec, at an air temperature of 20°C.

Short pipe conductance

From the Clausing's factor "K" and the hole conductance "C" in the drawing below (Clausing's factor drawing), the short pipe conductance C_K is easily found as $C_K=KC$.

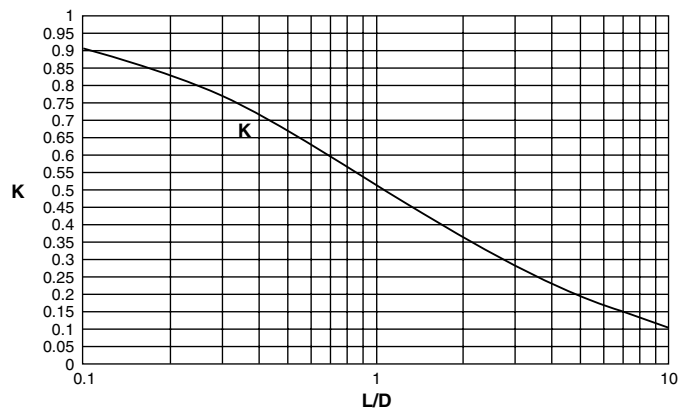

Graph 1. Clausing's factor

Conductances combined

When each of the separate conductances are given as C_1 , C_2 and C_n , the composite conductance ΣC is expressed as:
 $\Sigma C=1/(1/C_1+1/C_2+\dots+1/C_n)$ when in series, and $\Sigma C=C_1+C_2+\dots+C_n$, when in parallel.

5 Outgassing

This is a phenomenon in which gases that are absorbed or adsorbed to chamber surfaces and/or its pores are released into the vacuum. It is lowest on smooth surfaces with a fine oxidize layer. The process of forming the oxidize layer has a particularly large effect. Reductions in outgassing can be achieved by methods such as EL processing to control the oxidation process in the case of aluminum alloys, and anhydrous high temperature oxidation in the case of stainless steel. Processes, such as anodization, can entrap gases in pores causing high outgassing rates. However, after high vacuum baking, the difference in the ultimate pressure with or without anodization is extremely minute.

6 Ultimate pressure

The ultimate pressure P (Torr) is $P=Q/S$, where the sum of the mass flow rates for outgassing (Q_g) and leakage (Q_l) is Q (Torr ℓ /sec) and the exhaust pumping speed is S (ℓ /sec). In cases of very low pressure, the exhaust characteristics of the pump itself may be the limiting factor. In particular, deterioration of pumping speed due to contamination of the pump by atmospheric moisture can be a major factor.

7 Exhaust time (low/medium vacuum)

The time (Δt) required to exhaust a chamber at low vacuum with volume V (ℓ), from pressure P_1 to P_2 , using a pump with pumping speed S (ℓ /sec) is $\Delta t=2.3 (V/S) \log (P_1/P_2)$. In high vacuums, this is subject to the ultimate pressure limit imposed by outgassing and leakage as characterized above.

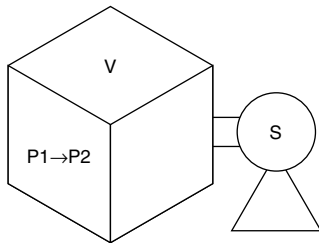

8 Baking

Gases such as oxygen and nitrogen, which have a small adsorption activation energy (E) and a short adsorption residence time (τ), are evacuated quickly. However, in the case of water, which has a high activation energy, evacuation does not progress quickly unless the temperature is raised to shorten residence time. This time may be characterized as $\tau=\tau_0 \exp(E/RT)$ where R is the ideal gas constant and $\tau_0=(\text{approx.})10^{-13}$ sec.

Residence time of water at 20°C is 5.5×10^{-6} sec, whereas at 150°C it is 2.8×10^{-8} sec, or 200 times shorter.

As an example, it took 800 minutes to evacuate moist air from a $\phi 150$ mm x 500 mm SMC test chamber to 10^{-9} Torr. The same process took only 4 minutes with dry (20 ppb) nitrogen.

9 Body materials

Stainless steel has been the traditional material for vacuum systems but the use of aluminum alloys is becoming more common. Stainless steel has good corrosion resistance and strength, but poor thermal conductivity causes large temperature variations, and heavy metal contamination is a problem. Aluminum offers superior temperature uniformity (with 12 times higher thermal conductivity) and in many cases better gas corrosion resistance. Also, it has lower sputter yields from stray energetic particles and contributes no heavy metal contamination. Special anodization is made available by SMC for highly corrosive gases.

10 Flow classification

The relation of the average free path of gas molecules λ and the pipe diameter D expressed as λ/D is the Knudsen number, and the relation of the pressure p (Torr) converted to air at 20°C is expressed as pD . These are the flow classifications shown in the table below.

Classification	λ/D (Knudsen number)	pD (Torr-cm)
Viscous flow	<0.01	>0.5
Intermediate flow	0.01 to 0.3	0.5 to 0.015
Molecular flow	>0.3	<0.015

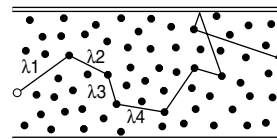

(a) When the pressure is high, there are many collisions among the molecules.

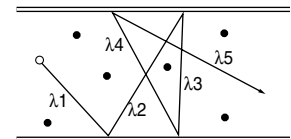

(b) When the pressure is low, collisions are mainly against the walls.

11 Partial pressure

This indicates the residual gas constituents in a vacuum (usually measured with a quadrupole mass spectrometer). At 10^{-7} to 10^{-9} Torr, 90% or more is moisture, at 10^{-12} Torr or below, 98% or more is hydrogen. The other main residual gases have mass numbers of 28 and 35. (from SMC data)

12 Total pressure

This is the sum of all partial pressures and is equal to $P=nkT$, where the pressure is P , the number of gas molecules is n , Boltzmann's constant is k , and the absolute temperature is T .

13 Average free path

This is the average flight distance (λ cm) that gas molecules travel between collisions with one another. It is inversely proportional to the molecular density (pressure) and may be characterized as $\lambda=0.7/\pi n\delta^2$ or $\lambda=2.33 \times 10^{-20} T/P\delta^2$. Here δ is the molecular diameter (cm), n is the molecular density (units/cm³), T is the absolute temperature (K), and P is the pressure (Torr). In the case of air, for example, this becomes approximately 5 cm at room temperature with 10^{-3} Torr. (Refer to the drawing in section 10 Flow classification.)

14 Impingement frequency

The impingement frequency of gas molecules on a unit surface area is $Z=3.53 \times 10^{22} P/(MT)^{1/2}$ collisions/sec cm² where M is the quantity of molecules, T is the absolute temperature (K), and P is the pressure. In the case of oxygen at room temperature and 10^{-6} Torr, one atomic layer impinges in a few seconds.

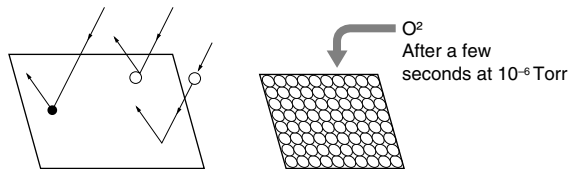

Auto Switch Specifications

Auto Switch Common Specifications

Type	Reed switch	Solid state switch
Leakage current	None	3-wire: 100 μA or less, 2-wire: 0.8 mA or less
Operating time	1.2 ms	1 ms or less ^{Note 2)}
Impact resistance	300 m/s ²	1000 m/s ²
Insulation resistance	50 MΩ or more at 500 VDC Mega (between lead wire and case)	
Withstand voltage	1500 VAC for 1 min. ^{Note 1)} (between lead wire and case)	1000 VAC for 1 min. (between lead wire and case)
Ambient temperature	-10 to 60°C	
Enclosure	IEC529 standard IP67, watertight (JIS C 0920)	

Note1) Connector style (D-A73C/A80C) and A9/A9 □V style: 1000 VAC/min. (between lead wire and the case)

Note 2) Except for solid state switch with timer (F7NTL) and solid state switch for strong magnetic field resistant 2-color display (D-P5DWL).

Lead Wire Length

Lead wire length indication

(Example) **D-M9P****L**

Lead wire length

Nil	0.5 m
L	3 m
Z	5 m
N*	None

* Applicable for the connector style (D-□□C) only.

Note 1) Lead wire length Z: 5 m applicable auto switches
Reed switch: D-A73 (C) (H), A80C

Solid state switch: All types are produced upon receipt of order.

Note 2) The standard lead wire length of solid state switch with timer or with water tight 2-color display is 3 meters. (Not available 0.5 m)

Note 3) The standard lead wire length of solid state switch for strong magnetic fields resistant 2-color display is 3 m and 5 m.

Note 4) For solid state switches with flexible wire specification, add "61" at the end of the lead wire length.

(Example) **D-F9PVL-61**

Flexible specification

Part no. of lead wires with connectors

(applicable only for connector type)

Model	Lead wire length
D-LC05	0.5 m
D-LC30	3 m
D-LC50	5 m

Auto Switch Hysteresis

Hysteresis is the distance between the position at which piston movement operates an auto switch to the position at which reverse movement turns the switch off. This hysteresis is included in part of the operating range (one side).

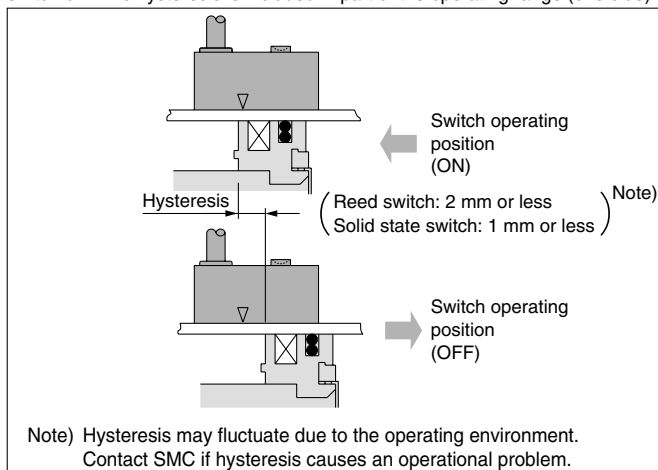

Contact Protection Box/CD-P11, CD-P12

<Applicable switch type>

D-A9 and D-A9□V, D-A7□(H), (C) and D-A80□(H), (C) type switches do not have internal contact protection circuits.

- ① The operated load is an induction load.
- ② The length of wiring to the load is 5 m or more.
- ③ The load voltage is 100 VAC and 200 VAC.

A contact protection box should be used in any of the above situations. The lifetime of the contact may be shortened.

D-A72 (H) must be used with the contact protection box regardless of load styles and lead wire length.

Specifications

Part No.	CD-P11		CD-P12
Load voltage	100 VAC	200 VAC	24 VDC
Max. load current	25 mA	12.5 mA	50 mA

* Lead wire length — Switch connection side: 0.5 m
Load connection side: 0.5 m



Internal Circuit

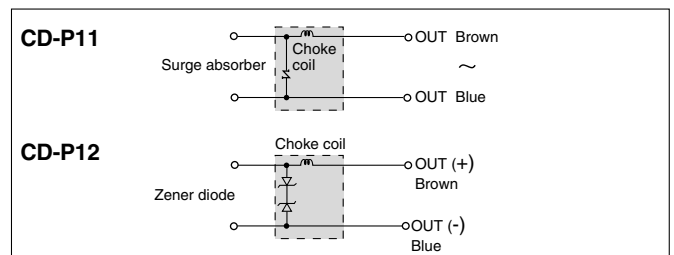

Dimensions

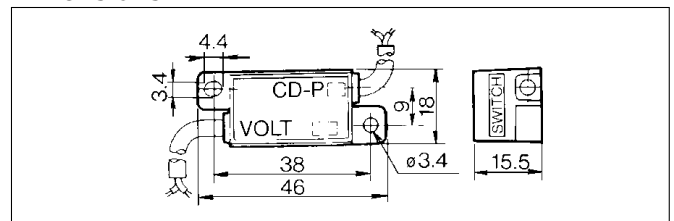

Contact Protection Box/Connection

To connect a switch unit to a contact protection box, connect the lead wire from the side of the contact protection box marked SWITCH to the lead wire coming out of the switch unit. The switch unit should be kept as close as possible to the contact protection box with a lead wire that is no more than 1 meter in length.

Prior to Use

Auto Switches/Connections and Examples

Basic Wiring

Solid state 3-wire, NPN

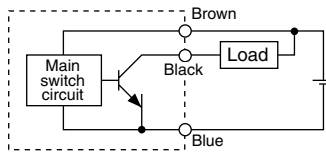

Solid state 3-wire, PNP

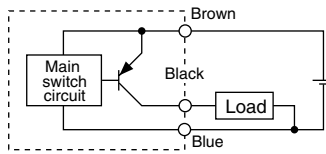

2-wire (Solid state)

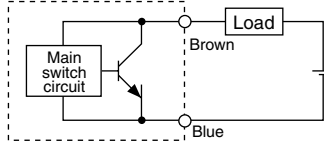

2-wire (Reed)

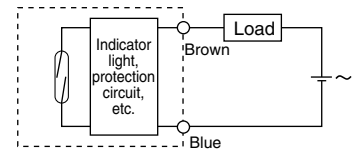

(When power supply for switch and load are separate.)

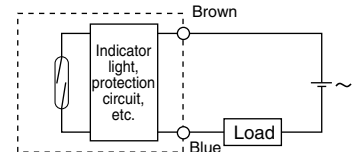
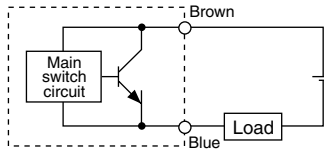
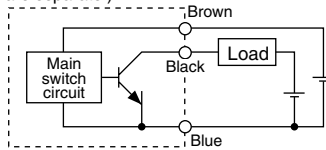

Examples of Connection to PLC

Sink input specifications

3-wire, NPN

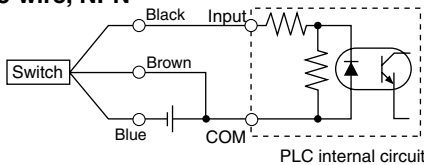

2-wire

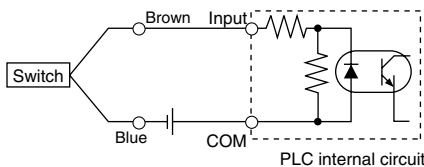

Source input specifications

3-wire, PNP

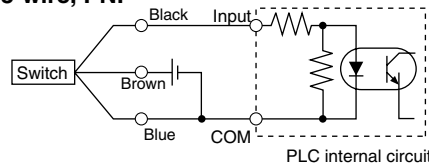

2-wire

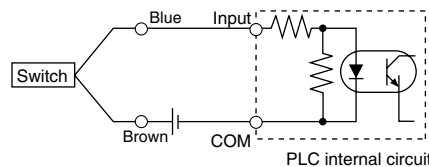

Connect according to the applicable PLC input specifications, as the connection method will vary depending on the PLC input specifications.

Connection Examples for AND (Series) and OR (Parallel)

3-wire

AND connection for NPN output (using relays)

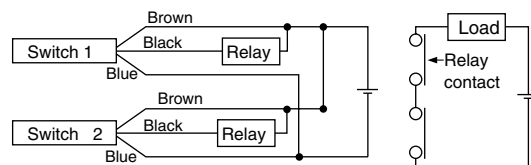

AND connection for NPN output (performed with switches only)

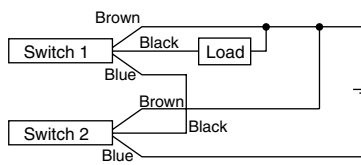

OR connection for NPN output

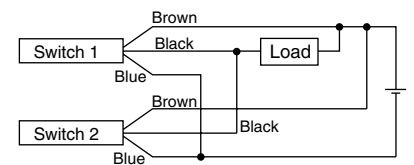

The indicator lights will light up when both switches are turned ON.

2-wire with 2 switches AND connection

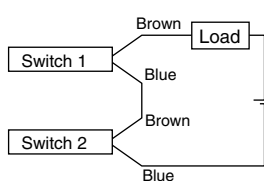

When two switches are connected in series, a load may malfunction because the load voltage will decline when in the ON state. The indicator lights will light up if both of the switches are in the ON state.

$$\begin{aligned} \text{Load voltage at ON} &= \text{Power supply voltage} - \text{Residual voltage} \times 2 \text{ pcs.} \\ &= 24 \text{ V} - 4 \text{ V} \times 2 \text{ pcs.} \\ &= 16 \text{ V} \end{aligned}$$

Example: Power supply voltage is 24 VDC
Voltage decline in switch is 4 V

2-wire with 2 switches OR connection

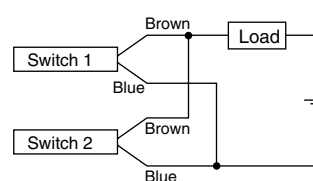

(Solid state)

When two switches are connected in parallel, malfunction may occur because the load voltage will increase when in the OFF state.

$$\begin{aligned} \text{Load voltage at OFF} &= \text{Leakage current} \times 2 \text{ pcs.} \times \text{Load impedance} \\ &= 1 \text{ mA} \times 2 \text{ pcs.} \times 3 \text{ k}\Omega \\ &= 6 \text{ V} \end{aligned}$$

Example: Load impedance is 3 kΩ
Leakage current from switch is 1 mA

(Reed)

Because there is no current leakage, the load voltage will not increase when turned OFF. However, depending on the number of switches in the ON state, the indicator lights may sometimes get dark or not light up, because of dispersion and reduction of the current flowing to the switches.

Solid State Switch: Direct Mounting Style

D-M9N(V)/D-M9P(V)/D-M9B(V)



For details about certified products conforming to international standards, visit us at www.smcworld.com.

Auto Switch Specifications

PLC: Abbreviation of Programmable Logic Controller

D-M9□, D-M9□V (With indicator light)						
Auto switch part no.	D-M9N	D-M9NV	D-M9P	D-M9PV	D-M9B	D-M9BV
Electrical entry direction	In-line	Perpendicular	In-line	Perpendicular	In-line	Perpendicular
Wiring type	3-wire			2-wire		
Output type	NPN		PNP		—	
Applicable load	IC circuit, Relay, PLC				24 VDC relay, PLC	
Power supply voltage	5, 12, 24 VDC (4.5 to 28 V)				—	
Current consumption	10 mA or less				—	
Load voltage	28 VDC or less		—		24 VDC (10 to 28 VDC)	
Load current	40 mA or less				2.5 to 40 mA	
Internal voltage drop	0.8 V or less				4 V or less	
Leakage current	100 μA or less at 24 VDC				0.8 mA or less	
Indicator light	Red LED lights when ON.					

Grommet

- 2-wire load current is reduced (2.5 to 40 mA)
- Lead-free
- UL certified (style 2844) lead cable is used.



Caution

Operating Precautions

Fix the switch with the existing screw installed on the switch body. The switch may be damaged if a screw other than the one supplied, is used.

Lead wires

- Oilproof vinyl heavy-duty cord: $\phi 2.7 \times 3.2$ ellipse, 0.15 mm²,
- D-M9B(V) 0.15 mm² x 2 cores
- D-M9N(V), D-M9P(V) 0.15 mm² x 3 cores

Note 1) Refer to page 55 for auto switch common specifications.

Note 2) Refer to page 55 for lead wire lengths.

Weight

Unit: g

Auto switch part no.	D-M9N(V)	D-M9P(V)	D-M9B(V)
Lead wire length (m)	0.5	8	7
	3	41	38
	5	68	63

Auto Switch Internal Circuit

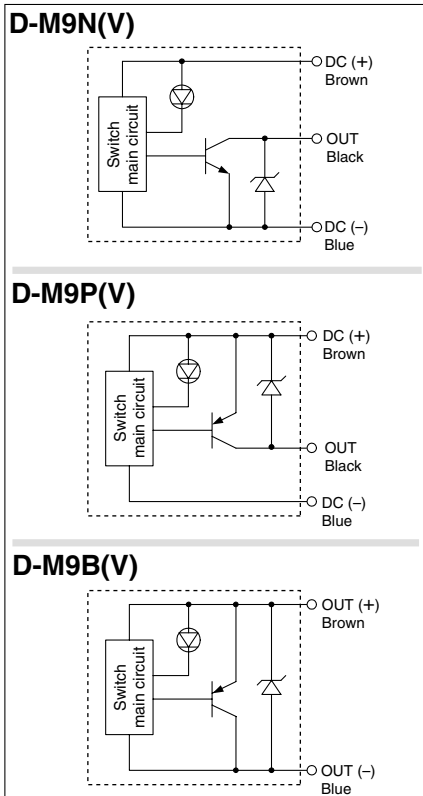

Dimensions

Unit: mm

D-M9□

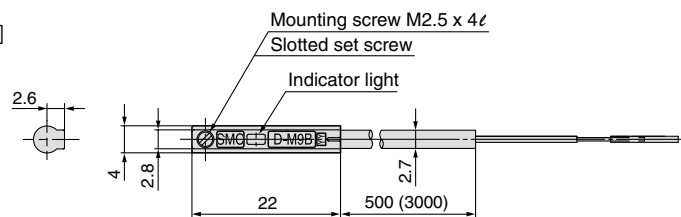

D-M9□V

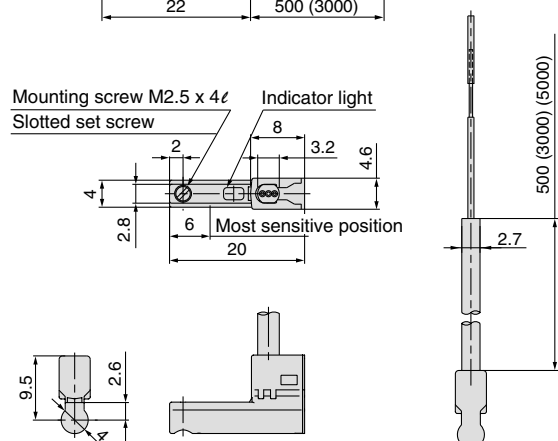

Reed Switch: Direct Mounting Style D-A90(V)/D-A93(V)/D-A96(V)



For details about certified products conforming to international standards, visit us at www.smcworld.com.

Auto Switch Specifications

PLC: Abbreviation for Programmable Logic Controller

D-A90/D-A90V (Without indicator light)			
Auto switch part no.	D-A90/D-A90V		
Applicable load	IC circuit, Relay, PLC		
Load voltage	24 V AC/DC or less	48 V AC/DC or less	100 V AC/DC or less
Maximum load current	50 mA	40 mA	20 mA
Contact protection circuit	None		
Internal resistance	1 Ω or less (including lead wire length of 3 m)		
D-A93/D-A93V/D-A96/D-A96V (With indicator light)			
Auto switch part no.	D-A93/D-A93V		D-A96/D-A96V
Applicable load	Relay, PLC		IC circuit
Load voltage	24 V DC	100 V AC	4 to 8 V DC
Load current range and max. load current	Note 3) 5 to 40 mA	5 to 20 mA	20 mA
Contact protection circuit	None		
Internal voltage drop	D-A93 — 2.4 V or less (to 20 mA)/3 V or less (to 40 mA) D-A93V — 2.7 V or less		0.8 V or less
Indicator light	Red LED lights when ON		

Grommet Electrical entry: In-line



Caution

Operating Precautions

Fix the switch with the existing screw installed on the switch body. The switch may be damaged if a screw other than the one supplied, is used.

Auto Switch Internal Circuit

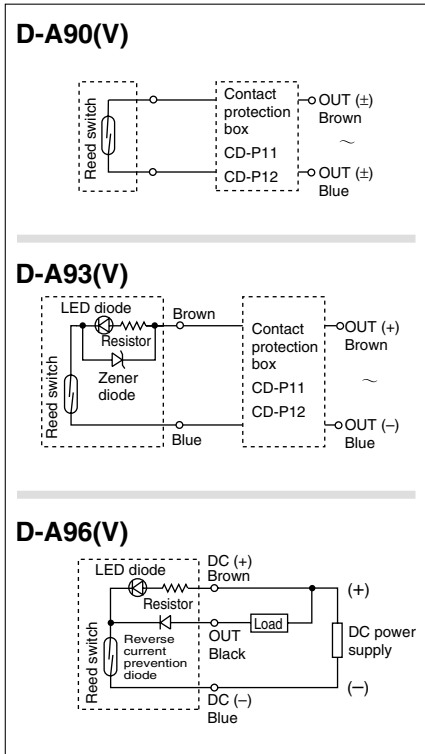

- Note) ① In a case where the operation load is an inductive load.
 ② In a case where the wiring load is greater than 5 m.
 ③ In a case where the load voltage is 100 V AC.

Please use the auto switch with a contact protection box any of the above mentioned cases. (For details about the contact protection box, refer to page 55.)

Weight

Unit: g

Model	D-A90	D-A90V	D-A93	D-A93V	D-A96	D-A96V
Lead wire length: 0.5 m	6	6	6	6	8	8
Lead wire length: 3 m	30	30	30	30	41	41

Dimensions

Unit: mm

D-A90/D-A93/D-A96

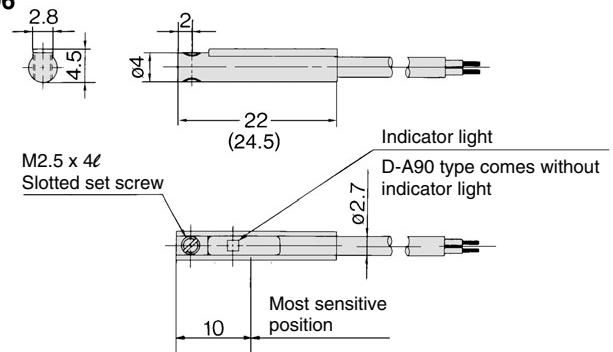

D-A90V/D-A93V/D-A96V

(): dimensions for D-A93.

